

## Rugged Washdown Sensing

### Clear Film Tension Control



S18U ultrasonic sensors control difficult-to-detect clear film on a horizontal form-fill-seal machine.

## Monitoring

### Machine Status Indication

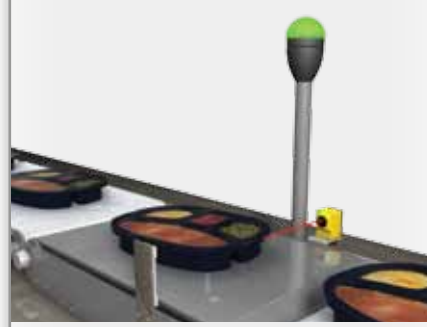

The EZ-LIGHT K50L, with a smooth rounded design and IP67/IP69K rating, provides worry-free status indication on check-weighing system.

## Quality Assurance

### Food Inspection

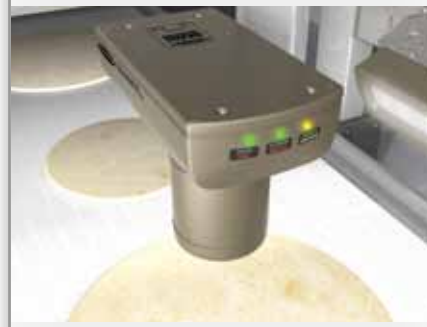

An IP68-rated *PresencePLUS* vision sensor measures diameter and colour quality of pizza crusts.

## Container Tracking

### Bottle Tracking During Washdown



IP69K-rated M25U ultrasonic sensor excels in juice and dairy industries. Smooth stainless steel housing cleans easily with no threads.

## Filling and Sealing

### Cap Inspection in Confined Spaces



Rugged, IP69K-rated Q12 sensor inspects bottle closure using fixed-field technology to ignore cap colour changes.

## Labelling

### Correct Container Verification



An iVu TG touch screen image sensor ensures boxes in any orientation are correct for food packaging.

## Packaging

### Leading Edge Detection



A QS18 adjustable-field sensor detects difficult-to-detect foil on flow wrapping machine.

## Traceability

### Date/Lot Code Verification

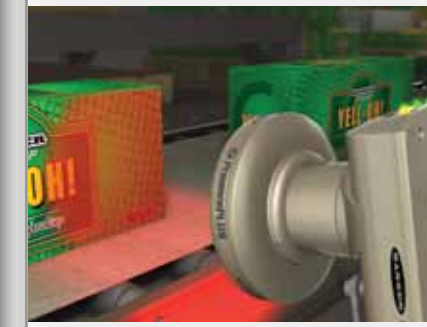

Prior to palletising, a sealed *PresencePLUS* vision sensor verifies a date/lot code has been printed.

## Safeguarding

### Robotic Palletising Safeguarding



One configurable SC22-3 safety controller monitors all safety devices in a robotic palletiser.

### Food Product Tracking



EZ-BEAM T18 fixed-field sensors detect leading edges of food package.

### Level Monitoring



QT50U ultrasonic monitors the level of problematic materials including clear liquids, hot slurry and frozen ice cream.

### Fill Level Verification



S18U ultrasonics with analog output accurately verify the level of liquids in container prior to sealing.

### Clear Object Detection



The 0,5 ms response time of the QS30 clear object sensor provides high-speed detection of clear, translucent and opaque objects.

### Fill Level Verification



IP69K-rated QS30H2O sensor is designed for clear liquid detection in plastic or glass containers.

### Registration Mark Detection



An R58 detects contrasts as low as 2% over a wide range of colours.

### Full Case Inspection



A *PresencePLUS* colour sensor ensures a bliss box has the correct number of bottles.

### Correct Label Verification



The iVu Bar Code Reader (BCR), with an integrated touch screen, reads a UPC and Data Matrix code to ensure the correct label is applied.

### Personnel Protection



A safety light screen protects employees from hazards on case erectors/sealers, case/tray packers and shrink wrapping systems.

### Beef Processing Line Washdown



Stainless steel *PresencePLUS* vision sensors provide inspection capabilities in a housing that withstands rigorous routine cleaning.

### Refrigeration Temperature Monitoring



A SureCross Node transmits conditions in refrigerators or freezers, minimizing product loss by issuing an alarm when temperature exceeds acceptable limits.

### Plastic Wrap detection



An IP67-rated QL56 luminescent sensor detects safety seals on cans prior to final packaging.

### Bottle Detection in Wet Environments



IP68-rated WORLD-BEAM QS18U ultrasonic sensor is ideal for space-limited applications where opposed-mode sensors will not fit.

### High-Speed Bottle Inspection



A *PresencePLUS* vision sensor inspects cocked cap, fill level, correct label, date/lot code and other features in washdown environments.

### Label Inspection



The iVu TG touch screen image sensor checks for torn, missing or incorrectly placed labels.

### Hot Glue Detection

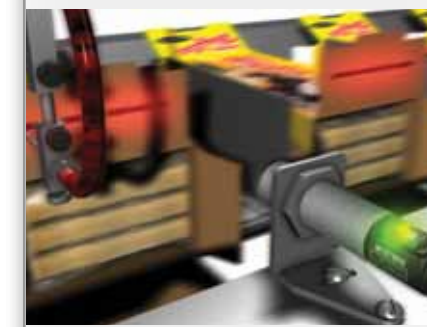

M18T temperature sensor detects the presence of hot glue before the flaps are closed.

### 1D/2D Bar Code Reading

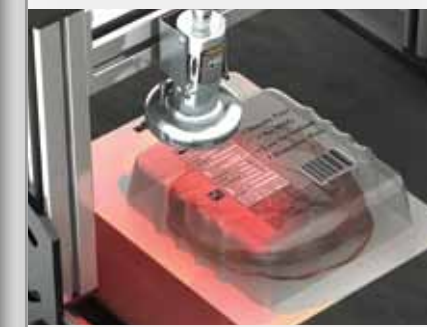

A stainless steel *PresencePLUS* vision sensor reads Data Matrix bar codes in washdown conditions.

### Collision Avoidance

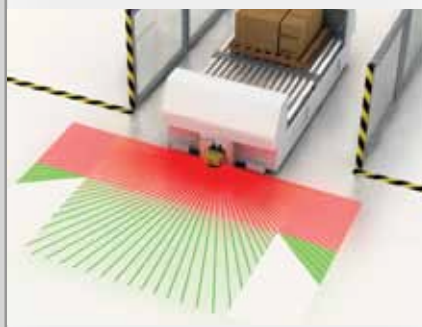

An AG4 two-dimensional safety laser scanner detects the presence of objects in the path of an automated guided vehicle (AGV).



# Industry Solutions for Food & Beverage



iVu Image Sensor



M25U Ultrasonic Sensor



EZ-BEAM Sensors



EZ-LIGHT Sensors

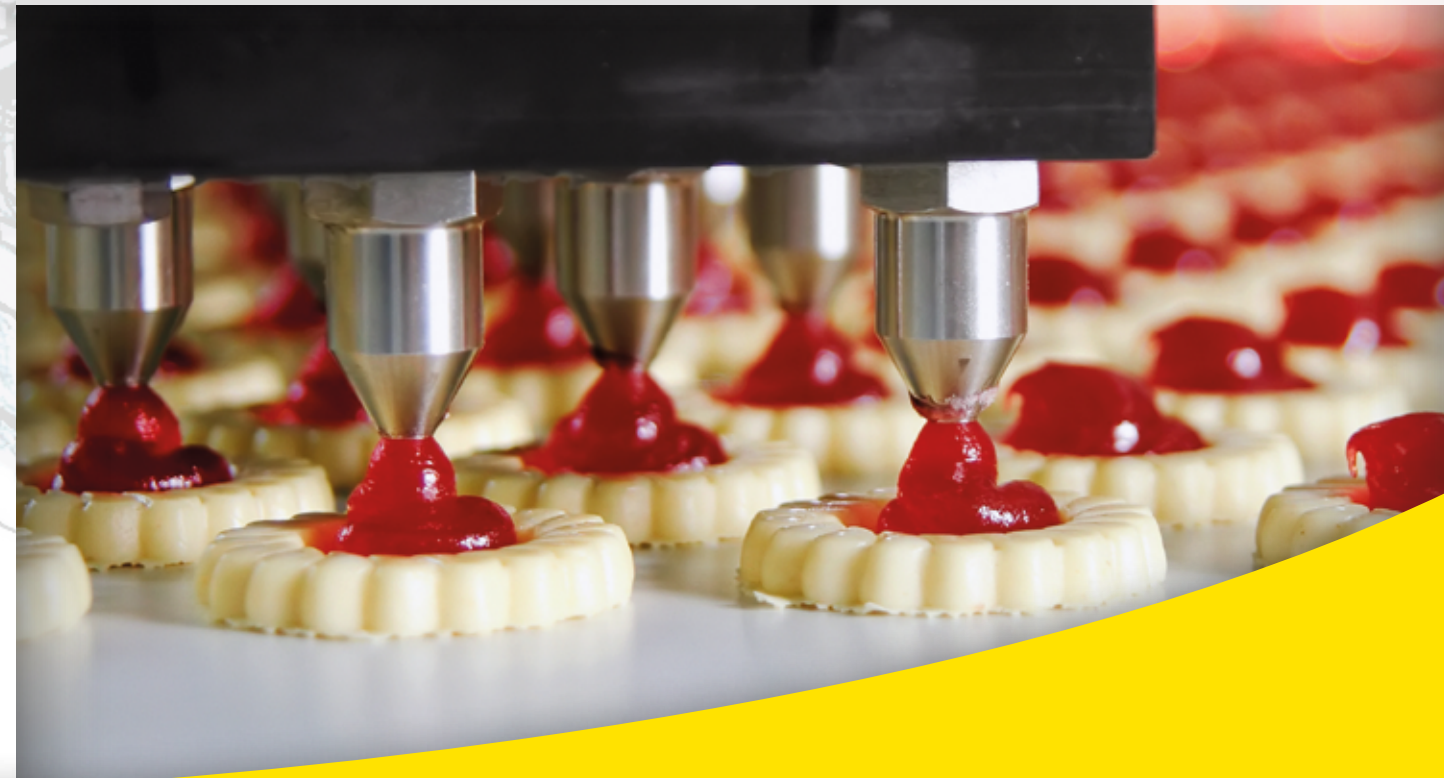

EZ-ARRAY Measuring Light Screens



R58 Colour Mark Sensors

## High-Pressure, Washdown Rated

IP69K rated sensors are extremely durable in hostile environments. Rugged, sealed housings protect electronic components. These sensors are ideal for washdown applications in food/beverage and pharmaceutical processes.

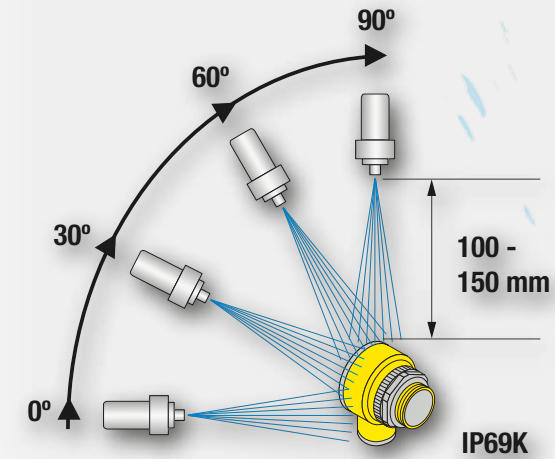

## Ecolab certification

Devices that are designed for use in areas of industrial hygiene are highly exposed to cleaning processes. Ecolab is a leading manufacturer of cleaning agents, and in its function as independent body, certifies and implements resistance tests, whereby industrial automation products are exposed to cleaning processes.



## High and low temperatures

The EZ-BEAM family operates under extreme temperature conditions: temperatures go as low as -40° and up to +70° C with shocked temperature.

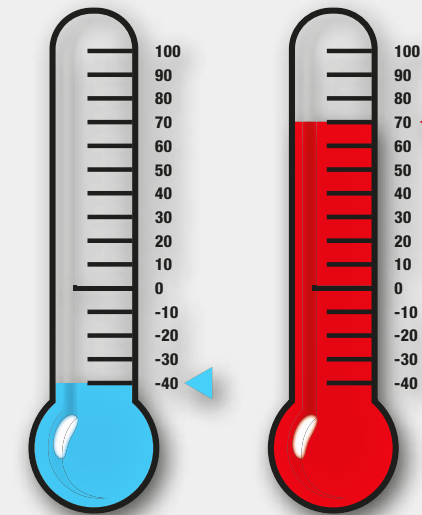

## Chemically Resistant

Chemical-Resistant sensor models are protected with a PFA chemical-resistant jacket. The LEDs are visible through the translucent PFA cover.

